

VK41..E, T

GAS CONTROLS WITH THROTTLE VALVE FOR AUTOMATIC IGNITION SYSTEMS

INSTRUCTION SHEET



SPECIFICATIONS

Models

VK4100 series: 220/240 Vrac, 50 Hz. two automatic shut off valves with pilot gas connection between the valves for intermittent pilot (IP) applications.

VK4105 series: 220/240 Vrac, 50 Hz. two automatic shut off valves for direct burner ignition (DBI) applications.

Suffix E: fast opening, throttle valve
Suffix T: softlite, throttle valve

Dimensions

See fig. 1.

Main gas connection

Inlet and outlet \varnothing 18.6 mm to be made with straight or elbow flanges

Inlet $3/8$ " ISO 7-1 internal parallel pipe thread and side outlet. \varnothing 14 mm.

Inlet and outlet G $1/2$ " or G $3/4$ " (external thread)

Inlet $3/8$ " ISO 7-1 internal pipe thread and straight or elbow flanges with $3/8$ " or $1/2$ " ISO 7-1 internal pipe thread are according to the torsion and bending stress of EN126 group 2

Connections with G $1/2$ " or G $3/4$ " external thread fitted with nuts according to ISO 228-1 in combination with applicable sealing(s) withstand the torsion and bending stress of EN 126 group 1

Pilot gas connection (where applicable)

4 mm outer diameter tubing.

Ambient temperature

0 ... 60°C

Minimum differential pressure

Between inlet and outlet: 2.5 mbar

Minimum adjustable capacity

0.6 m³/h air at ΔP of 20 mbar

Maximum operating pressure

The P_{max} indication on the housing is the maximum inlet pressure at which the combination gas control functions safely.

Electrical data

Coil indication	Supply voltage
220/240 Vrac	220 V, 50 Hz using rectifier 240 V, 50 Hz using rectifier

APPLICATION

VK41..E, T gas controls have been specially developed for application in domestic and small commercial atmospheric appliances with automatic ignition.

VK41..E, T gas controls are used in a system context in conjunction with either a direct burner ignition (DBI) or intermittent pilot (IP) control module and associated devices to provide programmed safe light-up and supervision of the main burner of an appliance.

VK41..E, T gas controls are intended to be used for manufactured, natural and LP gases (1st, 2nd, 3rd family gas).

VK41..E, T gas controls are approved in accordance with existing european standards.

DESCRIPTION

VK41..E, T gas controls comprise of two electrically operated shut off valves in series, a throttle valve and a slow opening mechanism.

The first valve is an automatic shut off valve of class B according to EN 161.

The second valve is an automatic shut off valve of class C or J according to EN 161.

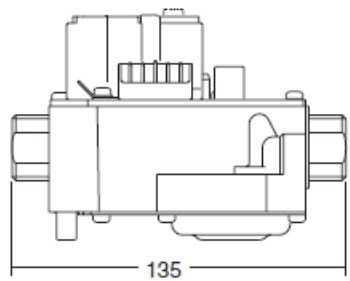
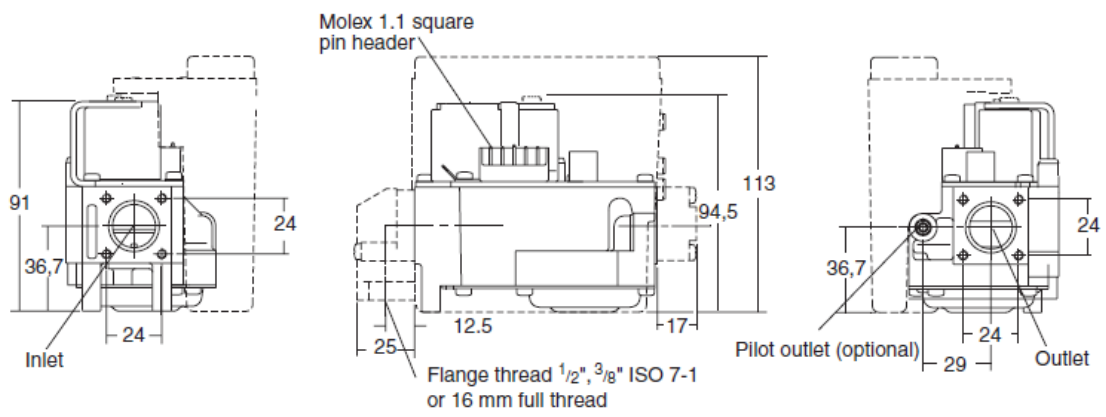
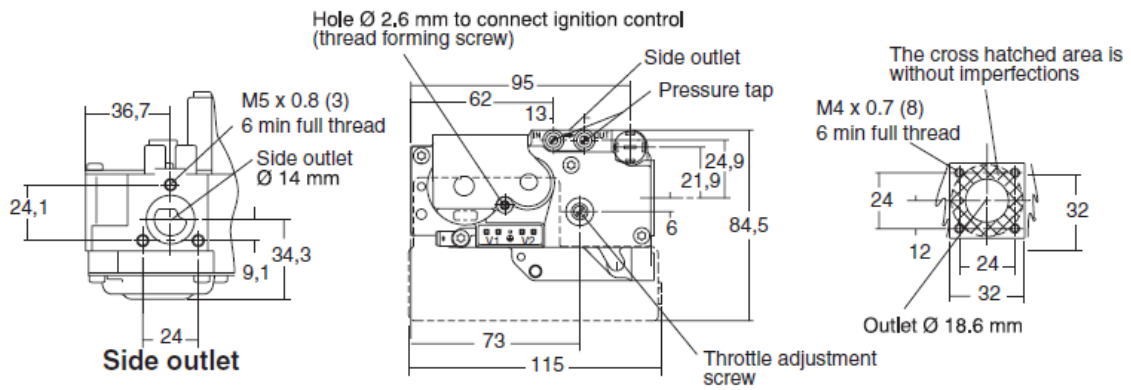

G $\frac{1}{2}$ " or $\frac{3}{4}$ " external thread

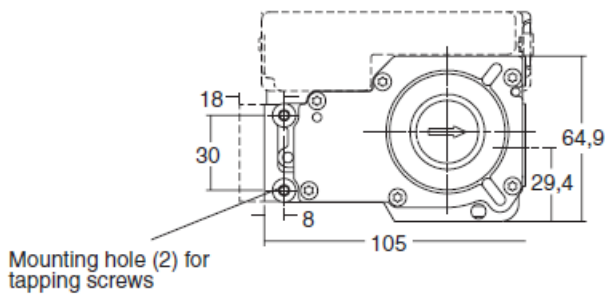

Tolerances according ISO 2768mK

Fig. 1. Dimensions

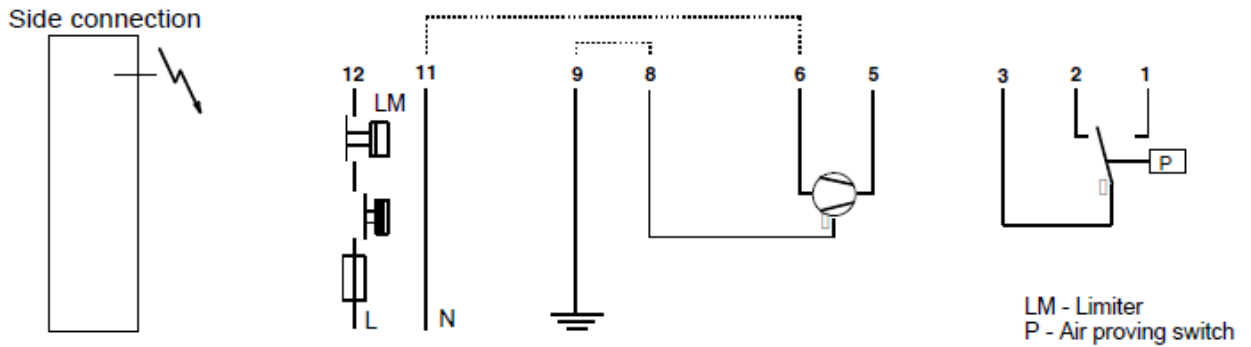

Fig. 2. Connection diagram S4585D wired up in fan assisted application

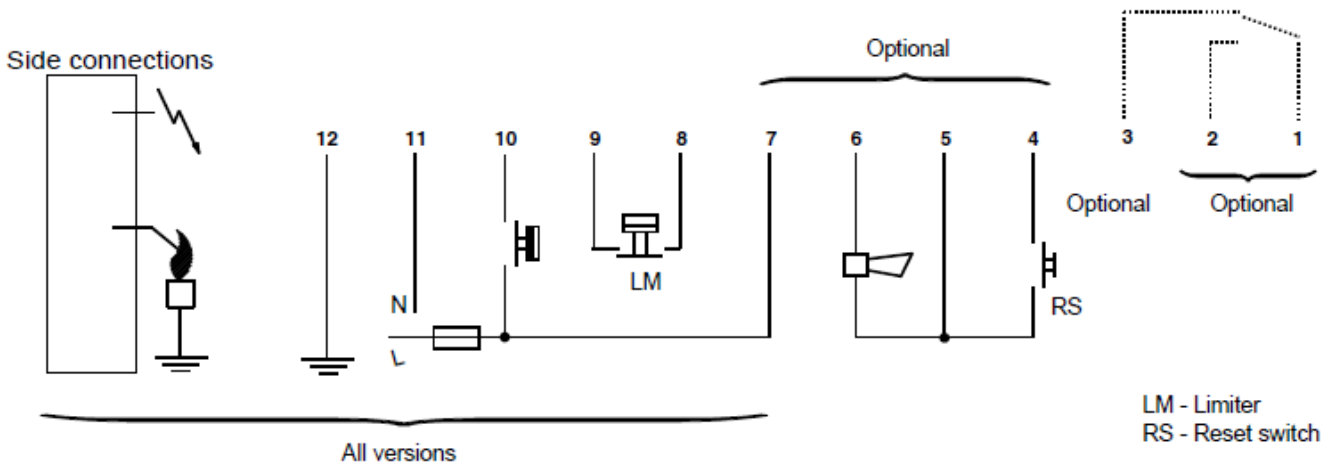

Fig. 3. Connection diagram S4565A, B, P and Q

Capacity

In m³/h air at pressure drop as shown below, for internal 1/2" ISO 7-1 or flanged versions.

Model	Valve classification		ΔP (mbar)	Capacity (m ³ /h air)	Capacity curve (on request)
	1 st valve	2 nd valve			
VK4100E, T/ VK4105E, T	B	J	3	2.8	H 160

NOTE: Increased capacity versions are optional. Versions with side outlet have a 0.2 m³/h lower capacity. Versions with 3/4" external thread connection have a 0.3 m³/h lower capacity.

Electrical connection

The gas control is designed to operate in cooperation with Resideo S4565 or S4585 series ignition controls. For **stand alone AC** applications in **direct burner ignition** applications a plug with rectifier circuit has to be used
Order number 45.900.441-

Timing (with operators vertical)

Closing time: < 1 s
Dead time: Fast open versions: 0.5 s max.
Softlite versions: see table 1.
Opening time: Fast open versions 1 s from start of flow till 80% of outlet pressure setting.
Softlite versions 1.5 s from start of flow till softlite pressure

IMPORTANT

Warranty claims are not accepted if not the specified plug/rectifier circuit is used.

Enclosure

IP 20: when used with S4565/S4585 series ignition controls with IP 44 option
IP 40: when used with plug 45.900.441-

Table 1:

Gas	Inlet pressure (mbar)	Dead time (s)
G 20/G 25	20	1.2 max.
G 30/G 31	37	1.5 max.
G 30/G 31	50	1.2 max.

Mounting holes

Two mounting holes for thread forming screws are located on the bottom of the gas control.

For versions with external thread there are two additional mounting holes for thread forming screws at the inlet side of the gas control.

The four holes at inlet and outlet side for mounting the flange to the gas control are provided with M4 thread with a minimum of 6 mm full thread.

Valve classification (depending on O.S. number)

1st valve: Class A or class B

2nd valve: Class C or class J

Current and power consumption

Nominal voltage	Current at nominal voltage (mA)		Power consumption at nominal voltage (W)	
	1 st operator	1 st + 2 nd operator	1 st operator	1 st + 2 nd operator
DBI system				
220 V, 50 Hz	--	48	--	9.4
240 V, 50 Hz	--	52	--	11.2
IP system				
220 V, 50 Hz	46	24	9.1	4.8
240 V, 50 Hz	50	26	10.9	5.7
IP system				
220 V, 50 Hz	31	31+11	7	7+2.2
240 V, 50 Hz	35	35+12.1	8	8+2.6

INSTALLATION

IMPORTANT

Take care that installer is a trained experienced service man.

Turn off gas supply before starting installation.

Disconnect power supply to prevent electrical shock and/or equipment damage.

Do not remove seals over inlet and outlet until the device is ready to be installed.

Take care that dirt cannot enter the gas control during handling.

Ensure the gas flows in the same direction as the arrow on the bottom of the gas control.

Mounting position

The gas control can be mounted 0 to 90 degrees in any direction from the upright position, i.e. from the position when electric operators are on top.

Main gas connection

Threaded pipe connection

- Use a clean taper fitting with thread according to ISO 7-1 or a piece of new, properly reamed pipe, free from swarf.
- Do not tighten the pipe or pipe fitting too far (see table below). Otherwise valve distortion and malfunction could result.

Pipe size	Max. length of pipe thread
3/8"	14 mm

1/2"	18.6 mm
------	---------

- Apply a moderate amount of good quality thread compound to the pipe or fitting only, leaving the two end threads bare. PTFE tape may be used as an alternative.
- Tighten gas control using the right open end wrench. See fig. 4.

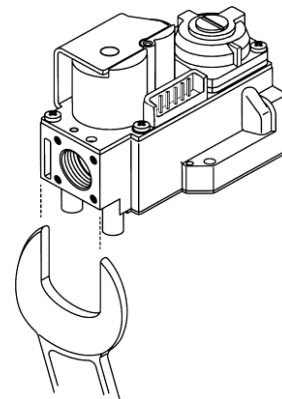

Fig. 4. Fig. 14.

Flange connection

- Insert "O"-ring in the groove of each flange, if necessary grease "O"-ring slightly to keep it in place.
- Mount gas control between flanges using the four screws for each flange.

External thread connection G^{3/4}"

☐ With nut and olive (see fig. 15.)

Pipe diameter: 15 mm
Fastening torque: maximum 50 Nm
minimum 30 Nm

Nut: drawing:45.004.583-003
Olive shall be suitable for Ø15 mm pipe.
Olives for this application are not supplied by Resideo.
Pipe end construction: square off end of tubing and remove burrs.

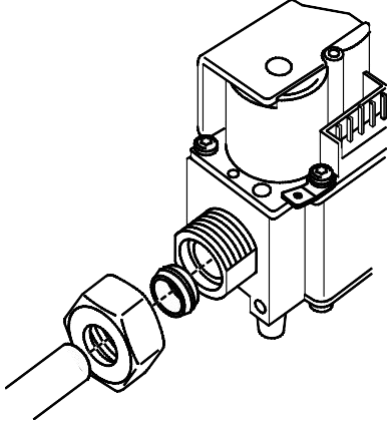
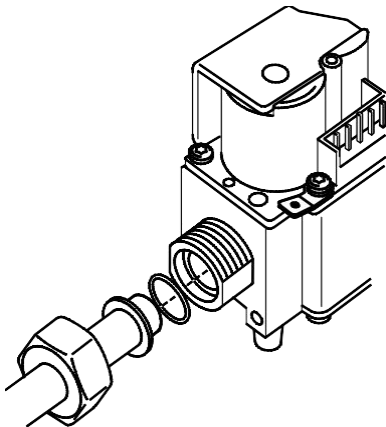

Fig. 5. External thread connection with nut and olive

⌘ With nut and "O"-ring (see fig 6.)

Pipe diameter: 15 mm
Fastening torque: maximum 50 Nm
minimum 10 Nm

Nut: drawing:45.004.583-003
"O"-ring size: Ø14.3 x Ø2.4 mm
drawing:.....45.004.528-048
Pipe end construction: see fig.: 8.



NOTE: Before fastening the nut be sure that the "O"-ring is proper placed on the pipe.

Fig. 6. External thread connection with nut and "O"-ring

⌘ With nut and flat sealing ring for pipe 15 mm (see fig 17.)

Fastening torque: maximum 50 Nm
minimum 30 Nm

Nut: drawing:45.004.583-003
Flat sealing ring size: Ø24 x Ø16 x 1.5 mm
drawing:.....45.004.582-001
Pipe end construction: see fig.: 9.

☐ With nut and flat sealing ring for pipe 18 mm (see fig 17.)

Fastening torque: maximum 50 Nm
minimum 30 Nm

Nut: drawing:45.004.583-002
Flat sealing ring size: Ø24 x Ø16 x 1.5 mm
drawing:.....45.004.582-001
Pipe end construction: see fig.: 10.

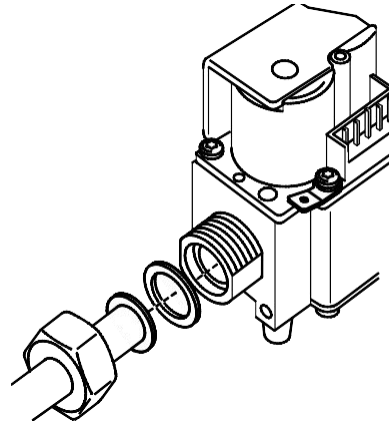

Fig. 7. External thread connection with nut and flat sealing ring



WARNING

Fastening torque flat sealing ring only applicable for type Klindergsil C4324

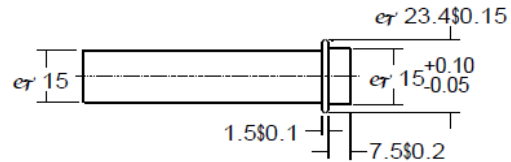

Fig. 8. Pipe end for "O"-ring connection for G^{3/4}" external thread



Fig. 9. Pipe (dia 15 mm) for flat sealing ring connection for G^{3/4}" external thread



Fig. 10. Pipe (dia 18 mm) for flat sealing ring connection for G^{3/4}" external thread

Pilot gas connection (VK4100 only)

- Square off the end of tubing and remove burrs.
- Slip compression fitting over tubing.
- Insert tubing into gas control housing until it bottoms, slide fitting into place and turn finger tight.
- Use a wrench to tighten fitting about $\frac{3}{4}$ turn beyond finger tight to make a pressure tight joint. **Do not use jointing compound.**
- Connect other end of tubing to pilot burner according to the pilot burner manufacturer's instructions.

CAUTION

Do not bend pilot gas tubing at gas control after compression fitting has been tightened, as this may result in gas leakage at the connection.

Remember that length of pilot tubing and pilot burner characteristics have influence on time to ignite pilot burner. This can interfere with available ignition timings.

Electrical connection

CAUTION

Switch off power supply before making electrical connections.

Take care that wiring is in accordance with local regulations.

To ensure a safe closing of the valve, it is essential that the voltage is reduced to 0 Volt.

Ensure that cut off function of limit control de-energizes both valves.

Use lead wire which can withstand 105°C ambient.

The electric on/off operators are with a single connector face suitable to receive Molex 3001 series female cable connector.

Wiring gas control in intermittent pilot (IP) systems

The appliance manufacturer's instructions should always be followed when provided. If not available see fig. 2. for typical systems using Resideo S4585 ignition control.

Wiring gas control indirect burner ignition (DBI) systems

The appliance manufacturer's instructions should always be followed when provided. If not available see fig. 3. for typical systems using Resideo S4565 ignition control.

Perform gas leak test

WARNING

FIRE OR EXPLOSION HAZARD CAN CAUSE PROPERTY DAMAGE, SEVERE INJURY OR DEATH

Check for gas leaks with a rich soap and water solution any time work is done on a gas control.

Gas leak test

- Paint all pipe connections upstream of the gas control with a rich soap and water solution. Bubbles indicate a gas leak.
- If a gas leak is detected, tighten the pipe connection.
- Stand clear while lighting the main burner to prevent injury caused from hidden gas leaks, which could cause flashback in the appliance vestibule. Light the main burner.
- With the main burner in operation, paint all pipe joints (including adapters) and gas control inlet and outlet with with a rich soap and water solution or an approved leak detection fluid.
- If another gas leak is detected, tighten adapter screws, joints and pipe connections.
- Replace the part if gas leak can not be stopped.

CAUTION

Keep soap and water solution away from electrical connections.

Be careful not to clog bleed vent parts with soap solution residue. Remember bleed vents will discharge air during gas valve opening or closing giving false indication of leakage.

ADJUSTMENTS AND CHECKOUT



WARNING

Adjustments must be made by qualified persons only. If the appliance manufacturer supplies checkout and/or service and maintenance instructions carefully follow them. If these instructions are not provided then use the procedure outlined below.

Pressure tap (see fig 1.)

The gas control is provided with a pressure tap of 9 mm outer diameter at inlet and outlet side.

When checking the pressure undo the screw a half turn and slip tube over nipple.

Ensure that pressure tap screw is retightened after making test.

Pilot flame (VK4100 only)



WARNING

It should be noted, that after a long time of stoppage (summer) it can take up to 60 s to come to an ignition of the pilot burner.

Outlet pressure adjustment (see fig. 1)

- Energize electric operators in order to have gas input to burner.
- Check input to the appliance using a clocking gas meter or alternatively a pressure gauge connected to the outlet pressure tap.
- Turn the throttle adjustment screw with a screw driver **in clockwise direction** to decrease and counter clockwise to increase the flow.

Check of slowopening (Softlite; VK41..T only)

The softlite pressure is factory set.

Check burner performance at this pressure observing burner ignition and flame characteristics.

Burner should ignite promptly and without flash back to orifice and all ports should remain lit.

Cycle burner several times (wait 10 seconds between cycles to allow servo system to resume slow open action).

Repeat check of slow opening after allowing the appliance to cool down.

Checkout

Set appliance in operation after any adjustment and observe several complete cycles to ensure that all burner components function correctly.

Maintenance and service

Under normal circumstances no maintenance or service is required.

Screws on the gas control that have been sealed must never be removed.

resideo

Resideo Pittway Sàrl

Z.A. La Pièce 4

1180 Rolle

Switzerland